



PC Tech Tips for the real world... This isn't your typical support page with only the obvious or easy questions. These solutions include the real-world, down-n'-dirty, nuts-n'-bolts, **hard** issues with **real** answers.

Home



WARNING: *Some of these solutions are for the advanced/expert/power user only. Use them at your own risk.*

1. My PC keeps locking up and crashing. [What should I do?](#)
2. I have to completely rebuild my machine. [How can I do that?](#)
3. Windows 95/98/ME doesn't do things like I want! [How can I customize?](#)
4. I backup my documents. [What else should I backup?](#)
5. I'm out of space! [What can I safely delete?](#)
6. I need an [ASCII Chart](#) or extended [ASCII Chart](#).
7. [Blackbox](#) cable specifications for [RS-232](#), [Tail Circuits](#), [Standard null modems](#), and [various connectors](#).
8. How do I create [successful web pages?](#)

Home

Copyright (c) 2002, Keith Turbyfill. All rights reserved.

























The Back Page



Personal Home Pages for [Keith Turbyfill](#)

The entire keithturbyfill.com website is [searchable](#).

 About Me	 Photo Album	 Timeless
 Best Utilities	 Choosing a PC	 Favorite Sites
 My Italian Greyhounds!	 Dog WebCam!	 A Few Favorite Dog Photos
 Huge Doggie Photo Album!	 PC Tech Tips	 Home Pictures
 Virginia Trip 2000!	 Like and not	 Mom's Homepage
 My UK Trip	 Online Resources	 My Turbyfill Name
 Turbyfills.com (Family name)	 Resume	 Skydive!
 SkyVenture!	 Universal Studios!	 Site Map and Descriptions



FREEDOM ENDURES

All materials Copyright (c) 2002 Keith Turbyfill unless otherwise noted. All rights reserved.



Search the Internet

Search this website

My PC Keeps Locking Up and Crashing

Back

Home



Solution: How Can I Stop My PC from Locking Up?

Important: Before working on serious problems on your PC, backup as many files as you can, even if only to diskette. Please note, some of these tips are for advanced users only!



There's nothing as frustrating as having your PC lock up or crash. Fortunately, there are several steps you can take to remedy the situation:

Uninstall last program installed. Many times, new programs introduce problems onto your system. See if the problem goes away by uninstalling the last program installed. Always uninstall using the Control Panel "Add/Remove Programs" or the program's own uninstall utility. If your PC has been "acting up" for a while, then you may have too many recently installed programs for this to help isolate the cause. Also note it is a very good practice to reboot before and after installing new programs.

Run Scandisk and Anti-Virus. If you're this far into troubleshooting, you've probably already done this. Be sure to get the latest Virus definitions from your anti-virus vendor.

Check Disk Free Space. The more current your version of Windows and Applications, the more free disk space is required. It is not uncommon now to need at least 300 to 400 free megabytes of space on the C: drive for computers to run properly. If you're tight on space, also consider "hard setting" the values for the sizes of your Temporary Internet cache (IE, Tools/Internet Settings) and your system swap size (Control Panel/System/Performance/Virtual Memory).

Clear out Cache and Temp files. If you don't have a program like Norton Utilities doing this automatically for you, consider manually cleaning out your c:\windows\temp folder, your Temporary Internet folders (use Internet Explorer Tools option on the menu bar and select "Internet Options" to delete temporary

files and cookies).

Check safe-mode Device Manager for duplicates. Boot into Safe-Mode on your computer by tapping the F8 key during boot. You'll be shown a menu from which you can select "safe-mode". Once in safe-mode, go into the Control Panel and double-click on "Systems". Go to the Device Management tab and expand all the entries. Look for duplicate entries for the same device. If you find any duplicate devices (by the same name, or the same device listed by two different names), then delete ALL the entries for that device and let Windows redetect the devices. You should remove all duplicates until you can boot into safe mode and not see any duplicate devices. Also check for and remove duplicate entries under the modems icon in Control Panel.

Obtain the latest drivers. Go the web sites and BBS's of the hardware manufacturers and get the latest drivers for all your hardware (video card, etc.). Don't forget to check for BIOS updates and system updates (i.e. PIIx).

Obtain the latest patches. Go the web sites and BBS's of the software you run on your system and get the latest patches and updates for all your programs. Also go to the [Windows Update page](#) and get all the Product Updates for your version of Windows.

Remove network card. An ill-configured or ill-running network card can cause some of the strangest problems ever seen on a PC. If you have a network card in your system, go into Control Panel and double-click on "Network". Record all your settings before you remove the network card from your system.

Turn off power management. Go into your system BIOS and turn off power management. You can usually get into your BIOS by pressing F2 or the "DEL" key during boot.

Check startup folder and icon tray. Look in the startup folder under the Start Menu, Programs and temporarily remove any non-essential "startup" programs. (You can remove or move items in the Startup folder by **right-clicking** and choosing "open" on the start button). Also look in the icon-tray on the taskbar and disable or shutdown as many background programs as possible. Usually, it's a good idea to make a new temporary folder and move the items in your startup folder rather than delete them.

CTRL-ALT-DEL and check contents. Under Windows 95/98/ME, when you press the CTRL-ALT-DEL, a task list will pop-up. Check and compare what's

running in your task list to what is *normally* running on your system when not having problems. You might spot a particular program running that's not usually there, or something new. If you don't know what your system was running before you had problems, you can also look on another PC to compare. You can also try ending all tasks except systray and explorer in the task list. If your system quits giving you problems, then you need to look in the startup folder, icon tray, win.ini, and "run once" (see below) to stop or remove all unnecessary programs from running when your computer starts.

Check autoexec.bat and config.sys. Sometimes new programs will make automatic entries in your startup files. Remove or remark out any lines that run programs you don't recognize. Be sure to make a backup copy of each file first.

Check for programs started in win.ini. The file win.ini in the c:\windows directory contains a "run=" and "load=" line. Remove or remark out with a semi-colon (;) any programs started in the win.ini.

Policy editor "run" items. If you don't already have it installed, use the Control Panel "Add/Remove" Windows components and install the Policy Editor. (Click the "Have Disk" button and browse to the Win95/98 Install CD and look in the Admin/AppTools/Poledit). After Policy editor is installed, you can open the Policy Editor under "Programs/Accessories/System Tools" and open the registry. Check the "Run" items in the System section under Local System. This will contain programs which are started when Win95 is started (similar to the run= line in the win.ini file). You *can also edit these items directly* by using the regedit utility and browsing to:

```
\\HKEY_LOCAL_MACHINE\Software\Microsoft\Windows\CurrentVersion
```

In the CurrentVersion section, you will find several "Run" folders containing programs that are automatically run each time you start Windows.

Rerun setup (no overwrite). Run the setup and do a "soft reinstall" of Windows 95/98 (run setup off the Win95/98/ME CD or your c:\windows\options\cabs folder). Do not overwrite any newer files which already exist on your system.

Rerun setup (overwrite). If the "soft reinstall" did not work, run the setup and overwrite all files. This will put you back at the "factory versions" for all your operating system files.

Reinstall the major "mainstream" applications. You need to do this

especially if you've reinstalled Win95 in the "overwrite" method described above. Programs like Microsoft Office, Microsoft Project, and other mainstream Windows 95/98/ME programs will not only implement themselves into the registry and setup, but they will typically put the latest versions of the program libraries and support files back onto your PC.

Norton Utilities (WinDoctor). Norton Utilities 3.0 and above have a very good diagnostic program called Norton WinDoctor. This program will analyze your system and help fix the most common registry problems. This product is also sold under a bundle called "Norton System Works". It does a very good job of keeping computers running smoothly.

Add RAM. Swap out your RAM, and if possible add additional memory to your system. Faulty or insufficient memory can cause strange problems on computers.

Upgrade Power Supply. Now this sounds weird, but I've seen on more than one occasion a flaky power supply cause strange problems on a system. This may be a job to take to a local computer store or vendor. It depends on what you're comfortable with. Modern systems use an ATX power supply connector which makes the connection much easier for the novice.

Rebuild the PC (Operating System). This is a drastic solution, and it is not for the novice user, but if all else fails, consider rebuilding from scratch. You need to know what you're doing, and be sure you have all your documents and files backed up. Also be sure to have your media and required serial numbers. A general rebuild guide can be found on the [Tech Tips](#) page.

Back

Home

Copyright (c) 2002, Keith Turbyfill. All rights reserved.

How Do I Rebuild My PC?

Back

Home



Solution: How Do I Rebuild My PC Operating System?

Important: Before working on serious problems on your PC, backup as many files as you can, even if only to diskette. This procedure is for Windows 95 and 98, but most of the general concepts apply to other versions as well, and may be helpful.



[View the detailed procedure online!](#)

Summary

Before starting a rebuild of a PC, there are several things you *must have* before you begin. These include:

- A valid copy of the FULL Windows 95/98 CD, or the Win95/98 CD Update and a Windows 3.1 Disk 1 diskette, You also need to have a valid certificate number that matches the Windows installation media.
- A bootable diskette (preferably a Win95/98 Startup diskette) with your CD-ROM drivers loaded in the config.sys and autoexec.bat.
- All your program diskettes, CD's, and serial numbers required for installation.
- A backup of your documents, configuration files, save files, and any other custom information you wish to transfer to your rebuilt PC.

There are several major steps to rebuilding a PC. Here is an **outline** of the most common installation method for reference:

- Boot from your bootable diskette and make sure you can get to the CD-ROM drive. Fortunately, Win98 Startup disks automatically setup most CD-ROM drives!
- Run the FDISK utility to remove any existing partitions, and then repartition the disk. Reboot the system from bootable diskette.
- Format the C: partition as bootable. Format the remaining partitions.
- Make the directory structure c:\windows\options\cabs on your hard drive.
- Copy the contents of the \WIN95 (or \WIN98 for Windows 98) folder on the Windows 95 CD to the c:\windows\options\cabs directory.

- Run SETUP.EXE from c:\windows\options\cabs. Be sure to NOT install to C:\WINDOWS.000 when prompted -- change the directory to C:\WINDOWS!
- After the installation and "First Time Windows" setup, customize your setup and load any additional hardware drivers/updates.
- Setup and test your baseline hardware and network (printers, scanners, dial-up networking, LAN, etc.)
- Install your oldest applications and utilities first.
- Install your most recent applications.

Finish by copying your documents and configuration files over to the rebuilt system. (See the [full document](#) for step-by-step instructions)

Back

Home

Copyright (c) 2002, Keith Turbyfill. All rights reserved.

How Do I Customize My PC?

Back

Home



Solution: How Do I Customize My PC?

Important: Before working on serious problems on your PC, backup as many files as you can, even if only to diskette.

The easiest and safest way to customize Windows 95/98/ME/2000 is to use shareware utilities and commercial programs.

The best shareware utility for customizing is tweakui, a utility included with a free download from Microsoft called **Powertoys**. Go to the [Microsoft Home Page](#) and go to the Downloads. In the downloads, look for Windows 95/98 add-ons. In the Add-ons, you'll find a link for the **Powertoys**.

Finally, one of the best utilities to customize and tune-up Windows 95/98 is Norton Utilities from Symantec. This package runs in the \$50 to \$75 range; however, it's one of the best utilities on the market, and well worth the price in my opinion.

Back

Home

Copyright (c) 2002, Keith Turbyfill. All rights reserved.

What Files Should I Backup?

Back

Home



Solution: What Files Should I Backup?

Important: Before working on serious problems on your PC, backup as many files as you can, even if only to diskette. A full backup to tape is best. Hey... Wait a minute... That's what this tip is about!

OK, obviously the best solution is to backup all your files on your hard drive(s) to a tape drive and a commercial backup utility (like Seagate's Backup Exec). But, not everyone has the time, space or money for tape drives and tapes. But you might have a ZIP disk or a hard drive with space on which you can make a backup folder. You can even use your diskette drive and a shareware utility like [Winzip](#) to add files to a spanned disk backup. Another good recovery method is to use Norton Ghost to make a full image of an entire disk partition! This is a great, inexpensive product which can make an exact snapshot of your entire system and place it in one large compressed file.



If you're backing up files in order to move or rebuild a system, don't forget things like your Windows\favorites folder, your .PST and .PAB files from Outlook (or data files from your own e-mail program), Data files from your tax or financial programs, Phone numbers and/or addresses from your FAX program, etc. These data files usually aren't stored in the My Documents folder!

Always keep a Windows boot disk (Startup Disk) with your CD-ROM driver working from the diskette. Be sure to test it by booting off the startup disk and making sure you can still use your CD-ROM drive.

Back

Home

Copyright (c) 2002, Keith Turbyfill. All rights reserved.

What Files Can I Safely Delete?

Back

Home



Solution: What Files Can I Delete?

Important: Before working on serious problems on your PC, backup as many files as you can, even if only to diskette.



Running out of space on the hard drive is something almost everyone runs into. One of the best tools to use to find and delete specific files is Windows Explorer, located on your start menu, under Programs. You can use the Tools option to Find (search) your hard drive for specific files.

Here's a fairly safe list of files to delete:

- All files and folders in the `c:\windows\temp` directory. It's best to reboot after cleaning out all the files you are able to delete.
- Backup copies of your `system.dat` file in your `c:\windows` folder made by other programs (for example `system.nu3`). Look for large files about the same size as your `system.dat` file, and don't delete your `system.ini` file! Also look for `user.dat` backup files (for example `user.nu3`).
- Files in your `c:\windows` files (and subdirectories) with a `.avi` extension. This will get rid of several relatively useless "help movies" which show you how to click on things...
- Any file on your drive with a `.tmp` extension or a tilde(`~`) as the first character of the extension (for example `myfile.~xx`)
- Look for files with extensions such as `*.old`, `*.bak`, `*.log`, `*.000`, `001`, etc.
- Empty your Netscape or Explorer cache (look in the options in the each program for a "delete cache files" button. In Internet Explorer, you'll find this under Tools, Internet Options).

- Use the "Find files or folders" in Windows Explorer Tools option and change the default search from the C:drive to "My Computer. Then click on the "Advanced" tab and search for all files larger than 2000 KB. Many times you can find temporary files or old large files you know are safe to delete.
- Empty the trashcan, and defragment the drive (look in the Start Menu under Programs, Accessories, System Tools, Disk Defragmenter).
- If you have multiple hard drives, try uninstalling games or programs and reinstalling them onto other drives.
- If you're really desperate for space, you can also hard set the value of your swap and temporary file space. Two values for advanced users to explore are the Browser temporary space (in IE it is under Tools, Internet Options, Settings), and the system swap space in the Control Panel, System, Performance, Virtual Memory.

Back

Home

Copyright (c) 2002, Keith Turbyfill. All rights reserved.

Dec	Hex	Char	Dec	Hex	Char	Dec	Hex	Char	Dec	Hex	Char
0	00	Null	32	20	Space	64	40	@	96	60	`
1	01	Start of heading	33	21	!	65	41	A	97	61	a
2	02	Start of text	34	22	"	66	42	B	98	62	b
3	03	End of text	35	23	#	67	43	C	99	63	c
4	04	End of transmit	36	24	\$	68	44	D	100	64	d
5	05	Enquiry	37	25	%	69	45	E	101	65	e
6	06	Acknowledge	38	26	&	70	46	F	102	66	f
7	07	Audible bell	39	27	'	71	47	G	103	67	g
8	08	Backspace	40	28	(72	48	H	104	68	h
9	09	Horizontal tab	41	29)	73	49	I	105	69	i
10	0A	Line feed	42	2A	*	74	4A	J	106	6A	j
11	0B	Vertical tab	43	2B	+	75	4B	K	107	6B	k
12	0C	Form feed	44	2C	,	76	4C	L	108	6C	l
13	0D	Carriage return	45	2D	-	77	4D	M	109	6D	m
14	0E	Shift out	46	2E	.	78	4E	N	110	6E	n
15	0F	Shift in	47	2F	/	79	4F	O	111	6F	o
16	10	Data link escape	48	30	0	80	50	P	112	70	p
17	11	Device control 1	49	31	1	81	51	Q	113	71	q
18	12	Device control 2	50	32	2	82	52	R	114	72	r
19	13	Device control 3	51	33	3	83	53	S	115	73	s
20	14	Device control 4	52	34	4	84	54	T	116	74	t
21	15	Neg. acknowledge	53	35	5	85	55	U	117	75	u
22	16	Synchronous idle	54	36	6	86	56	V	118	76	v
23	17	End trans. block	55	37	7	87	57	W	119	77	w
24	18	Cancel	56	38	8	88	58	X	120	78	x
25	19	End of medium	57	39	9	89	59	Y	121	79	y
26	1A	Substitution	58	3A	:	90	5A	Z	122	7A	z
27	1B	Escape	59	3B	;	91	5B	[123	7B	{
28	1C	File separator	60	3C	<	92	5C	\	124	7C	
29	1D	Group separator	61	3D	=	93	5D]	125	7D	}
30	1E	Record separator	62	3E	>	94	5E	^	126	7E	~
31	1F	Unit separator	63	3F	?	95	5F	_	127	7F	□

Dec	Hex	Char	Dec	Hex	Char	Dec	Hex	Char	Dec	Hex	Char
128	80	Ç	160	A0	á	192	C0	Ł	224	E0	α
129	81	ù	161	A1	í	193	C1	ł	225	E1	β
130	82	é	162	A2	ó	194	C2	Ṛ	226	E2	Γ
131	83	â	163	A3	ú	195	C3	ł̇	227	E3	π
132	84	ä	164	A4	ñ	196	C4	—	228	E4	Σ
133	85	à	165	A5	Ñ	197	C5	†	229	E5	σ
134	86	ã	166	A6	ª	198	C6	‡	230	E6	μ
135	87	ç	167	A7	º	199	C7	‡	231	E7	τ
136	88	ê	168	A8	¿	200	C8	Ł	232	E8	Φ
137	89	ë	169	A9	ƒ	201	C9	Ṛ	233	E9	Θ
138	8A	è	170	AA	¬	202	CA	Ł	234	EA	Ω
139	8B	ï	171	AB	½	203	CB	Ṛ	235	EB	δ
140	8C	î	172	AC	¼	204	CC	‡	236	EC	∞
141	8D	ì	173	AD	¡	205	CD	=	237	ED	∞
142	8E	Ë	174	AE	«	206	CE	‡	238	EE	ε
143	8F	Ä	175	AF	»	207	CF	±	239	EF	∩
144	90	É	176	B0	⋮	208	DO	Ł	240	FO	≡
145	91	æ	177	B1	⋮	209	D1	Ṛ	241	F1	±
146	92	Æ	178	B2	■	210	D2	Ṛ	242	F2	≥
147	93	ó	179	B3		211	D3	Ł	243	F3	≤
148	94	ö	180	B4	†	212	D4	Ł	244	F4	
149	95	ò	181	B5	‡	213	D5	Ṛ	245	F5	
150	96	û	182	B6	‡	214	D6	Ṛ	246	F6	÷
151	97	ù	183	B7	Ṛ	215	D7	‡	247	F7	≈
152	98	ÿ	184	B8	Ṛ	216	D8	‡	248	F8	°
153	99	Ö	185	B9	‡	217	D9	↓	249	F9	•
154	9A	Û	186	BA		218	DA	Ṛ	250	FA	·
155	9B	÷	187	BB	Ṛ	219	DB	■	251	FB	√
156	9C	£	188	BC	Ł	220	DC	■	252	FC	π
157	9D	¥	189	BD	Ł	221	DD	■	253	FD	²
158	9E	₤	190	BE	↓	222	DE	■	254	FE	■
159	9F	f	191	BF	Ṛ	223	DF	■	255	FF	□

RS-232 INTERFACE

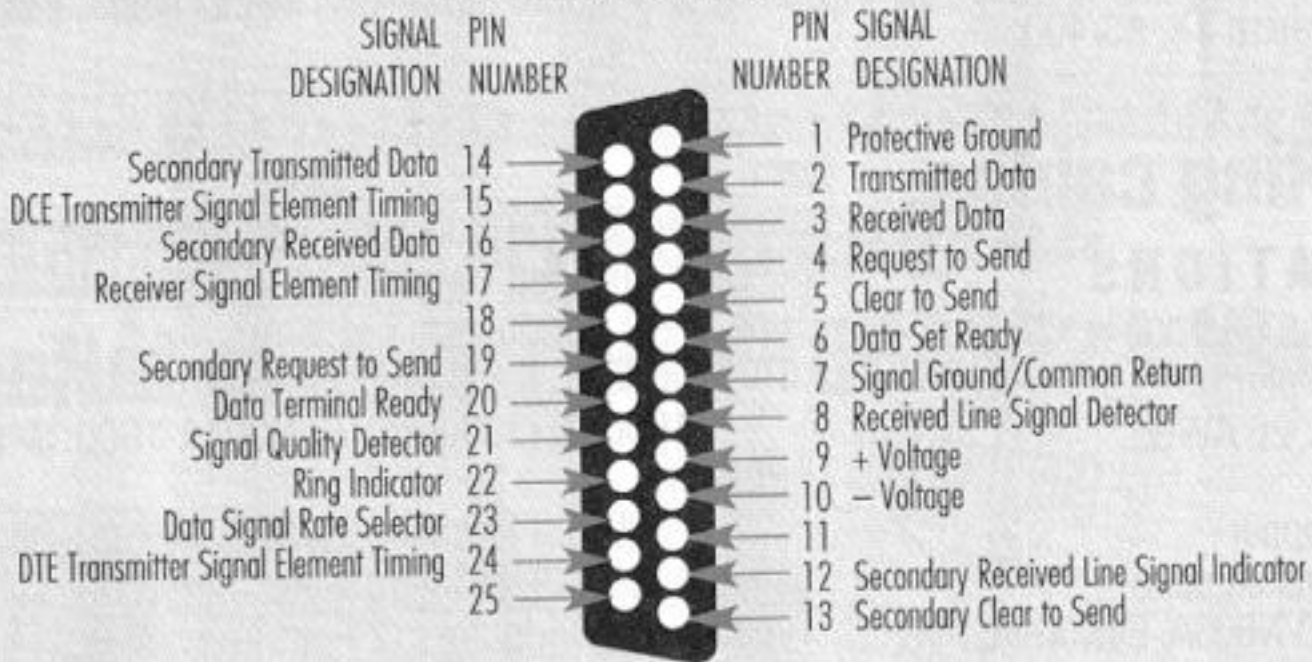

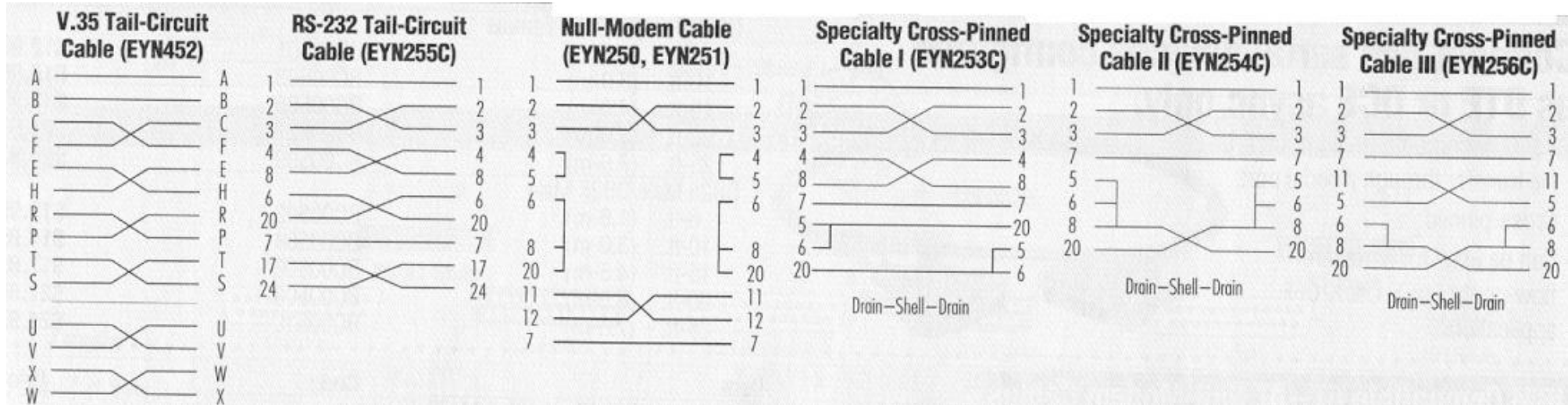

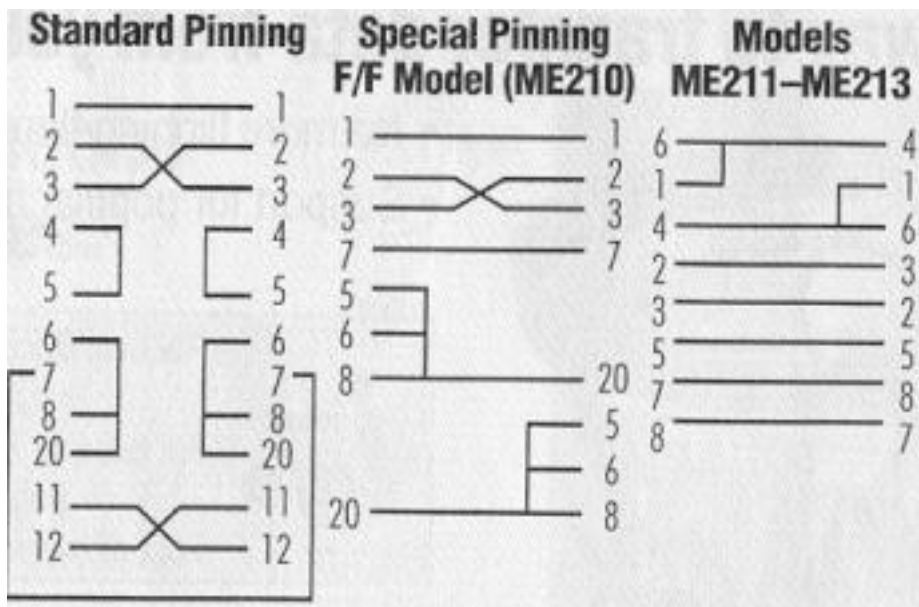

DB-Type Connectors



DB9



DB15



DB25



DB37



DB50

Centronics Connectors



Centronics® 36 (Male)
(Telco 36)



Centronics 50 (Male)



MDR 36 (Male)
(IEEE 1284)

HD-Type Connectors



HD 15



HD 15-Pin Video (Pin 9 Keying)



HDI 30-Pin (Male)

USB Connectors



USB Type A (Host)



USB Type B (Device)

Modular Connectors

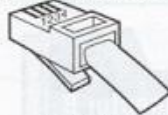

RJ-11 4-Wire

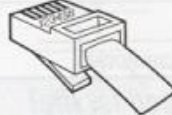

RJ-12 6-Wire

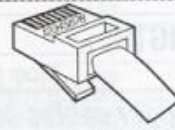

RJ-45 8-Wire



RJ-11 (4-, 6-, 8-Wiring)



MMJ

SCSI Connectors



Telco or Centronics 50
(SCSI-1 Male)

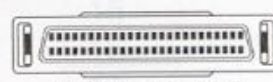

Mini D 50 or Micro DB50
(SCSI-2 Male)

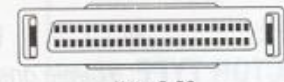

Micro D 50
(SCSI-2 Male)



Micro D 68
(SCSI-3 Male)



DB50
(SCSI-1, Sun® Male)



Micro D 50 M Thumbscrew
(HP® Male)



Burndy 68
(IBM® Male)



Burndy 60
(IBM Male)



VHDCI 68
(0.8-mm Champ-Style Male)

DIN-Type Connectors



4-Pin Mini DIN
(Female)



5-Pin DIN
(Female)



6-Pin Mini DIN
(Female)



8-Pin Mini DIN
(Female)

Fiber



Fiber Connectors



V.-Type Connectors



Coax & Twinax Connectors



Miscellaneous Connectors



Successful Web Pages

Home



How Do I Create Successful Web Pages?



Lots of people ask me for advice on creating web pages, and more often how to be found on search engines. Here are my suggestions:

Editing Tools. The first thing to get is the right editing tool for your level of expertise. Professionals tend to use tools such as Frontpage, Dreamweaver, or any of several other commercial products. Beginners may want to start with something like Microsoft Publisher or even Microsoft Word to create web pages. Another great web creation method for novices are the simplified on-line creation tools such as [Homestead](#) and [Tripod](#). These online providers provide truly easy-to-use web creation environments for beginners.

Titles, first words, and Meta Tags. If you're looking to bring people to your web site, you first have to have content that folks want to see. No amount of tips, tricks, or skullduggery will overcome the basic premise of content. *You are here now reading this* because you're interested in the topic. You probably found this web page through a search engine. The best way to be found on a search engine is to come up in the *search results*. While you can submit your site to be listed in the search engine categories, I have found the following to be the *best* way to help people find you on the web:

1. **Page Title:** In HTML, this is the text between the <TITLE></TITLE> directives at the

top of your web page. In my experience, a good title is the **single most important factor in being picked up** on search engines, and having people click on it to come to your site. Many experts will tell you to make the title long -- and to stuff in as many descriptive words as possible -- I believe the title should be short and descriptive. Think about it. When *you're* using a search engine, are you likely to click on the link with dozens of synonyms, or the link that is a short clear description of what you're interested in seeing?

2. **First Words:** The first few words on your web page are golden. These first words should be in plain text (not graphics). They should describe in one or two sentences what is on the page. Think of those first few words as a description field in the search engine for your web page -- because that's exactly what they are on many search engines.
3. **META tags:** Meta Tags are HTML directives which provide overall information or instructions for your web page. Here is an example of using META tags as a useful tool for your readers and search engines:

```
<title>How Do I Create Successful Web
Pages?</title>

<meta name="author" content="Keith Turbyfill">

<meta name="keywords" content="create, page,
search, found, success, find, engine, meta,
tag, seen, great, Internet, techniques, tips,
tools, domain, style, design">

<meta name="description" content="How to
create web pages that are found by search
engines and seen by others on the Internet. A
few common techniques that will help you
create great web pages.">

<meta name="robots" content="all">
```

The first entry, <TITLE>, is not a META tag, but illustrates what I was saying about an appropriate title rather than a title filled with keywords. The second entry, the META tag for "**author**" should contain your name. It's also not a bad practice to include a copyright notice on your web pages as well. Next, you'll see the META tag for **keywords**. Use this entry to specify all the individual words you think people might use when searching for your web page (Note: Some search engines ignore all words after about the tenth). Then include a **description** META tag. This description content should be similar to the "first few words" described earlier. On many of my pages, I use *exactly* the first couple of sentences that are displayed on my web page as the description META tag content. This entry should be one or two sentences that succinctly describe what is on your web page. Finally, you may also include the **robots** META tag entry as shown above. This is simply a

directive for the search engines as to the scope of searching on your page. On some pages, you may not want (or it is not necessary or useful) to have a search engine parse the entire content. If you're wondering -- yes you can set these types of tags using the "easy-to-use" tools such as [Homestead](#).

Layout. Layout and style is important if you want people to stay and view additional material (let alone buy something). My general recommendation is to keep the layout simple. Some of the layout and design tips below will seem to some as restrictive; however, if you want to keep your web site viewable by the largest possible audience, it is good advice. In the end, *you'll* need to decide for yourself what fits your target audience and creative requirements.

Bright is better. Unless the mood of your site demands it, brighter tends to provide a better experience. Most graphics tend to work and look better on a plain white (or at least solid) backgrounds. As a rule, avoid the cheesy multi-color backgrounds.

Lots of White Space. Think vertical. Try to keep plenty of blank space on the pages, particularly on the sides. Avoid at all costs making readers scroll left-to-right on your page. Scrolling *down* typically isn't a problem. White space on the side is also important from a practical sense. Not everyone has their monitors set to (or a system capable of) high resolution. The rule of thumb is to make it no wider than viewable on a 800x600 resolution screen. I usually keep my pages at 640x480. To see what I mean, set your screen resolution to 640x480, 800x600, or 1024x768. Come back and look at this page. The layout remains the same. Try the same thing on other websites. In some cases you'll find disaster! One of the easiest and most common ways of controlling width is to put your page content in tables. For example, the example HTML code below will display text in a column 500 pixels wide, just like the one on this page:

```
<table border="0" width="500">
<tr>
<td>
<font face="Arial">
Lots of people ask me for advice on creating web
pages, and more often how to be found on search engines. Here are
my suggestions
</font>
</td>
</tr>
</table>
```

Hard set the Background and Foreground Color. This is one a lot people forget. Don't leave the background and foreground to automatic or default! The result of not setting a default color scheme can make your page look terrible (or render your website unreadable) on many systems! Use your editor page properties or the HTML `<BODY>` directive to set the colors. For example:

```
<body bgcolor="#FFFFFF" text="#000000">
```

keeps this page on a white background with black text as the default. The same concept holds true for the default font used on your web page.

Use Basic Fonts. This seems to be the hardest thing for novices to do. There are only a few universal fonts (i.e. Courier, Arial, Times New Roman, etc.) Using a very cool font may look great on your system -- but it may look terrible on thousands of other computers that don't have that same font. Stick with the basic fonts for all your text. If you really need a special font for a title or heading, put it in a small graphic and insert the graphic. That way, everyone will see the same thing.

Keep a common look and feel. Try to keep a common theme for your website. In addition to the colors, and graphics, make sure you stay consistent in navigation. Try to always have the same navigation buttons in the same places on various pages, etc.

Keep Frames to a minimum. Framed pages tend to turn into big headaches. Sometimes there is no better solution that to use a framed page (several independent windows in a single browser window). Usually, this is done for navigation, for example, to keep certain buttons or content up on the top or side while changing the content window beside). Avoid frames until you experiment and learn all the unexpected behavior they can cause (for example, when someone finds one of your pages from a search engine and opens it up without your frame -- or when someone else's frame opens your frame inside of their frame!). It's best to learn how to deal with all of these issues before publishing framed pages.

Avoid sounds and motion. Yes. You may be thinking "*What?! Isn't that what interactive is all about?*" The problem is that too many people overuse sounds and motion. Most readers tend to find it annoying. Music and sound effects drive many readers away immediately. The best advice I can give you is to avoid sound and motion like the plague. Then, when you find the occasion that you just can't resist, it will probably work well, and add function or interest to

your website.

Optimize. If you use photos or graphics on your website, learn to optimize file size. **Stop.** Don't go anywhere else. Don't do *anything* else before you learn how to optimize!

Let's cover the basics now: As an example, if you have all your graphics in the JPG format, open them up in a graphic editor. Find the JPG file options when you choose "File Save As". Somewhere in the options when saving (or in the options on the menu bar) you'll find a setting (usually a slider bar) for setting the size and/or quality of the JPG. In most cases, you can take this down to around 30 to 50 percent and *still have a good looking picture*.

It makes the difference between having a graphic that is several hundred KB and one that is 20 KB. It *makes the difference* between having a web page that loads in a few seconds and one that takes a LONG time to load. Finally, for photographs, learn how to resize the photos to 640x480 or 800x600. Again smaller size and quick loading is the key.

If you don't have a graphics program, you can try some good shareware ones such as [Lview](#) or Paint Shop Pro. You can also try a free program like [Irfanview](#) that will do basic file saving options and picture resizing.

Inspiration vs. Theft. One of the best ways to make a great website is to look at what works! Take another look at the web sites you use a lot (or can find easily in a search engine) and see what works for them! There's nothing wrong with creative inspiration derived from the works of others. Personally, I doubt any of us have had a *truly independent* creative thought -- it's always influenced by our experience and the works of others. The trick is to create, add, shape and alter what you found on someone else's page to be unique enough to call your own. Don't go out, steal, and use other people's content as your own. The correct thing to do is:

1. Steal it. (For lack of a better description).
2. Figure out how it was done.
3. Recreate it.
4. Repeat the creation several times until you understand it.
5. Modify and alter it.
6. Find similar tools and methods for creating it.
7. Then, go out and create something new for you.

At this point, you've probably done enough to call it your own. If you doubt it, ask the person who's work you looked at for inspiration and ask them to take a look. In my experience, you'll get an honest

answer, and usually help in creating your work. If the original author is unhappy, you're probably not deriving inspiration and learning "public" techniques, but stealing someone's work. Start over.

It's a thin line between inspiration and theft. We're all probably a lot more wobbly on that line than we'd like to admit. When in doubt, stay off the side of theft.

Search Engine Submission. This is a tough one. I know there are a lot of people who encourage you to pay them to drive traffic to your site. I'm not saying all of these are scams, but some are. Frankly, getting listed in a category isn't always useful. What counts is your page link coming up within the first few pages of a search. Good content, titles, and meta tags do more to make this happen than anything else. If you're dead set on getting listed in search engines, at least go with a big name company with a money back guarantee on getting listed (for example [Microsoft's bCentral](#) services as of Feb/2002).

Counting and Tracking. Once you have a web site up and running, you should add counting code to each page so you can find out where people are going, what type of systems they are using (browser, screen resolution, colors, etc.). Most importantly, you can find out what search words they are using and which search engines they are coming from. You can get a basic free counter at www.sitemeter.com. It will provide reports all of the information mentioned here. All you have to do is sign up and insert the code they give you on the bottom of each of your pages.

Take a look at the bottom of *this* page. You'll see a number. I've added a counter to some of my pages to illustrate counting and tracking. Click on the number and you'll go to the summary report page for this counter. You'll be amazed at the amount of helpful information that is available.

Domain Name. Finally, I recommend a domain name for anyone serious about web traffic. It's not that hard to do once you have your web page up. The easiest (but more expensive) way is to go to a big player like [Yahoo! Domains](#) and sign up for a domain name that points to your web site. There are lots of cheaper alternatives, but these *sometimes* require you do and understand more, and *sometimes* these less expensive vendors have more operating problems (system problems, down time, etc.) than the "big players".

Would you like to try a sample? Here's a [simple template](#) web page filled with line by line comments illustrating and explaining the recommendations made here.

[Back](#)

[Home](#)

Copyright (c) 2002, Keith Turbyfill. All rights reserved.